



INFLATABLE BOATS



Carefully read this manual before operating your Achilles.

The manual is supplied as part of the boat, please keep it in a safe place and hand it over to the next owner when selling the boat.

ACHILLES INFLATABLE BOATS

Congratulations on your purchase of an Achilles Inflatable Boat. Boaters like yourself have made Achilles one of the most popular inflatable boats in the world.

Your Achilles has been manufactured using the most modern advances in inflatable boat design and technology. It is made with a tough overall fabric consisting of a heavy-duty nylon or polyester base impregnated with ※C.S.M. outside and ※CR inside.

This combination makes your Achilles second to none in term of toughness and durability. All this means you can look forward to many years of safe, reliable service from your Achilles.

To enjoy your Achilles to the fullest, take the time to read this manual carefully, and be sure to familiarize yourself with the sections on Maintenance and Safety.

※C.S.M.

CHLOROSULFONATED POLYETHYLENE

※CR

CHLOROPRENE

CONTENTS

The Achilles Process	4
Design and Standard Features	6
Assembly	12
Floorboards	12
Inflation	13
Motor mount	15
Outboard Motor	16
Optional Equipment	17
Maintenance	17
Repairs	18
Safety Guidelines	19.20
Seating Guide Lines	21
Notice	21
LIMITED WARRANTY	22
SPECIFICATIONS & C. E. ANNEX	

THE ACHILLES PROCESS

KEEPING A COMMITMENT TO QUALITY.

Every Achilles boat produced represents our best effort. As soon as we find a way to improve our boats, whether through a design alteration, new fabric treatment or feature refinements, it is incorporated into our new models. This is made possible by the flexibility of our modern production facility.

We do this because of our commitment to quality.

Our goal is to produce the finest boats possible and the Achilles Process is how we achieve this. What is the Achilles Process? It is an ongoing effort that combines experience, research and technology to insure top, state-of-the-art quality.

We have, however, remained consistent in our assembly process. Achilles still assembles our boats the "old fashioned" way-hand glued with C.S.M. adhesives. Despite claims of new, improved manufacturing techniques, Achilles process assures time proven results. The Achilles Process guarantees that every boat we produce represents our best possible effort, and that we will always work to improve that effort.

At Achilles, there is only one level of quality. We don't produce "bargain" or secondary lines.

That is how we built our strong reputation, and that is how we will maintain it now and forever.

USING THE MOST ADVANCED TECHNOLOGY.

Our modern production facility was designed for one purpose only: to produce inflatable boats. It boasts a computerized manufacturing system which insures speed, efficient and, most importantly, quality control. Achilles also uses a Computer-Aided-Design(CAD) System for designing boats. This CAD capability allows us to develop new designs and features, as well as refine existing ones, faster and more accurately than traditional design methods. This means that we can explore many more design alternatives than our competition.

Our modern technology allows us to remain on the leading edge of inflatable boat innovation. When you buy an Achilles Boat, you are buying the most advanced inflatable boat on the market.

MAKING SOPHISTICATED DESIGN REQUIREMENTS.

Our technology allows us to make changes quickly and efficiently. But it is a combination of experience and research that dictates what these changes will be.

Because of our commitment to quality, we have developed a policy of ongoing research. But there is no substitute for experience. So what we have learned from all previous boats and models over the years goes into our new inflatables. This results in a gradual process of subtle design refinement.

We know there are many manufactures' producing "rubber" oriented inflatable boats, however it takes years of experience and dedication to produce a high performance inflatable "boat". That is, an inflatable boat that performs and maneuvers like a rigid hull boat. At Achilles, yearly design refinements have seen our boats evolve not only into superior inflatables, but into outstanding boats as well.

PRODUCING THE BEST FABRIC.

The fabric is the single most crucial element of any inflatable boat. And there is no fabric tougher or more airtight than the unique four-layer fabric Achilles uses on each and every boat.

We start with a heavy-duty nylon or polyester core material produced to our own exact specifications. This tough fabric is then strengthened further with two durable man-made elastomers, C.S.M. and CR.

C.S.M. is a superior additive for resisting damage from abrasions, punctures, oil, gasoline or the weathering effects of the sun, ozone and warm salt water. And Achilles uses an industry high 80% C.S.M. compound developed through years of experience

and testing.

This high concentration of C.S.M. is not simply coated over the exterior but actually joined to the base fabric through a high pressure "calendering" method. Calendering insures a dense, even, impermeable fabric. Two layers of CR are calendered inside Achilles boats since this elastomer is tear resistant, flexible and externally airtight.

Adding the extra layer of CR guarantees complete airtight coverage. Although C.S.M. and CR are expensive elastomers, we do not try to cut costs by substituting less expensive fabrics as some other manufacturers do.

And unlike some other manufacturers, we not only use our same top quality fabric on every boat we make, we also use it on every part of our boats.

TAKING EXTRA SAFETY STEPS.

A strong emphasis on safety is part of the Achilles Process. No other inflatable boat manufacturer takes the time and effort to incorporate so many safety "extras" into their boats.

For example, no one else reinforces seams both inside and out with seam tape. Achilles also overlaps the fabric a full inch at the seams as compared to the industry standard of approximately one-half inch. Our strong seam construction combined with our glue control method, uniform curing process and special valve design, help guarantee the most airtight boats in the industry.

Achilles boats are also built with multiple air chambers. In fact, you will never find a competing boat with more air chamber than a comparable Achilles model. This is another important Achilles safety feature.

Our impressive list of safety of safety extras goes on and on. We take the time and effort to guarantee boats of uniform strength through an expensive controlled heat curing method. Our inflation valves are double-capped for safety. We take extra steps to insure airtightness. In short, we build safety into every Achilles boat.

ADDING AND IMPROVING STANDARD FEATURES.

An important result of the ongoing Achilles Process has been the development of a number of innovative standard features for our boats. And because of our commitment to producing the highest quality boats on the market, we believe in selling "complete" inflatables fully equipped with a broad range of standard features which other manufacturers offer as options or not at all.

For example, we developed the advanced fold-down, locking oar system you'll find on most Achilles boats. This innovative system not only secures oars in place, it also allows them to be folded down out of the way when not in use.

Achilles was the first to design the fast, easy self-locking floorboard system offered with all our sportboats and sport dinghies. We introduced light weight, non-corrosive aluminum floorboards which assemble using the same simple system. Almost all our boats come with one or more seats specially designed to complement that boat and the uses it will encounter. These items and such features as extra bow rings for securing gear, safetygrip handles, fuel tank fasteners, and motor mount pads have been developed in response to consumer needs and suggestions. At Achilles, our boats are people-oriented, not factory-oriented. That is, we are willing to design and adapt our boats to meet the practical needs of boaters as opposed to designing them to conform to factory production capabilities.

DESIGN AND STANDARD FEATURES FOR MOST DINGHIES

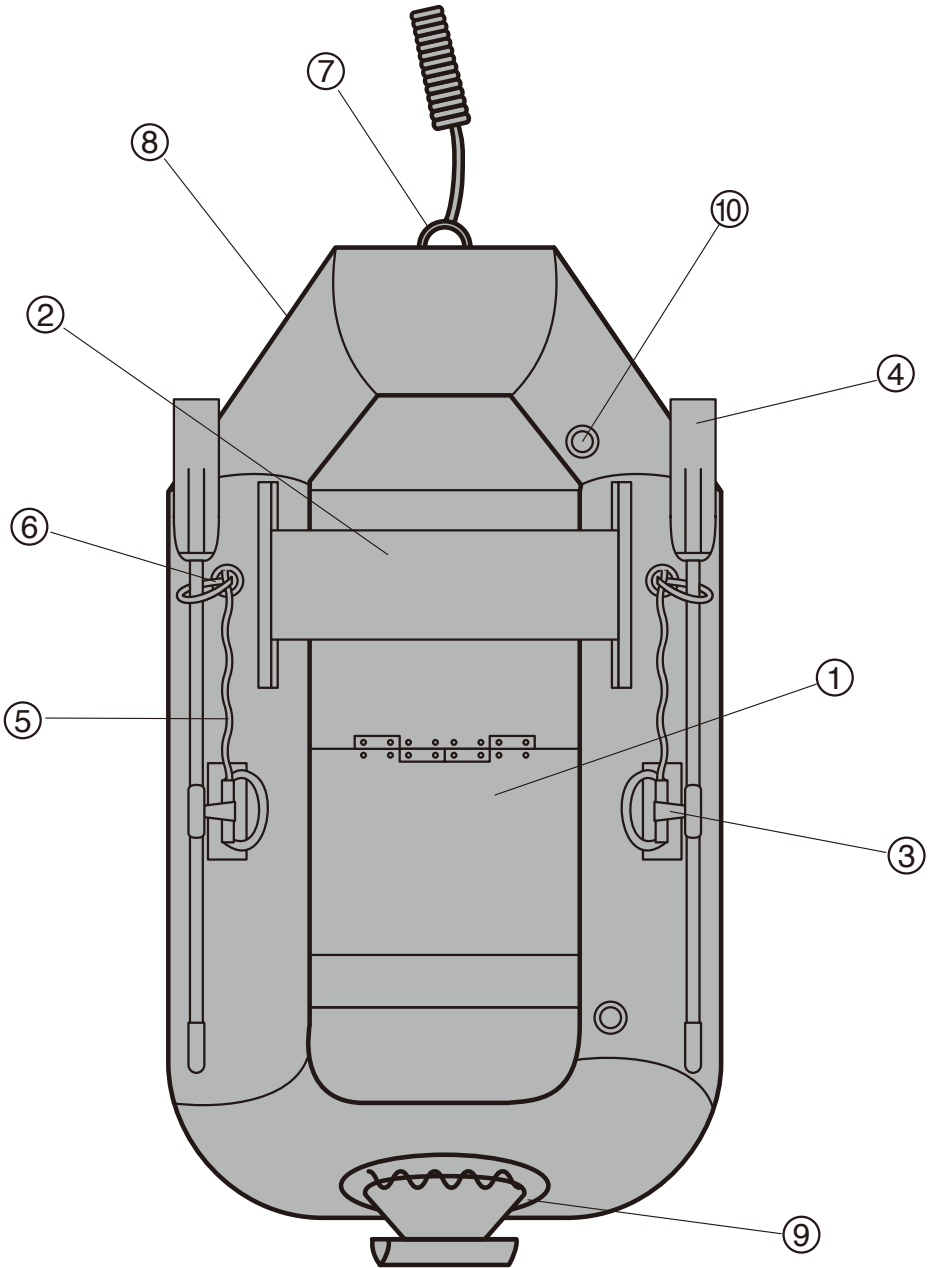

1. Hinged or Fabric joined Marine Plywood Floorboards for added stability. Fold up for easy storage when not in use. marine grade paint.
2. Wood or Aluminum seat
3. Lock-Type Oarlocks.
4. Aluminum and Plastic Collapsible Oars. Specially made for Achilles Dinghies.
5. Lifelines: Attached with stainless steel "D" rings.
6. Oar holders on most models for additional oar support when not in use.
7. Stainless Steel Towing "D" Rings on most models fastened in molded rubber with reinforced Nylon for stronger and safer towing. Painter line included.
8. Reinforced Rubbing Strip: Extra wide, thick rubber for protection.
9. Outboard Mounting Bracket.
10. Achilles Extra Large Check Valve for quick deflation, unscrew cap and valve together.

Note: To determine which features are standard on a particular model, Please refer to Achilles Brochure or check with your Achilles Dealer.

DESIGN AND STANDARD FEATURES FOR MOST SPORT & HEAVY-DUTY MODELS WITH TRANSOM

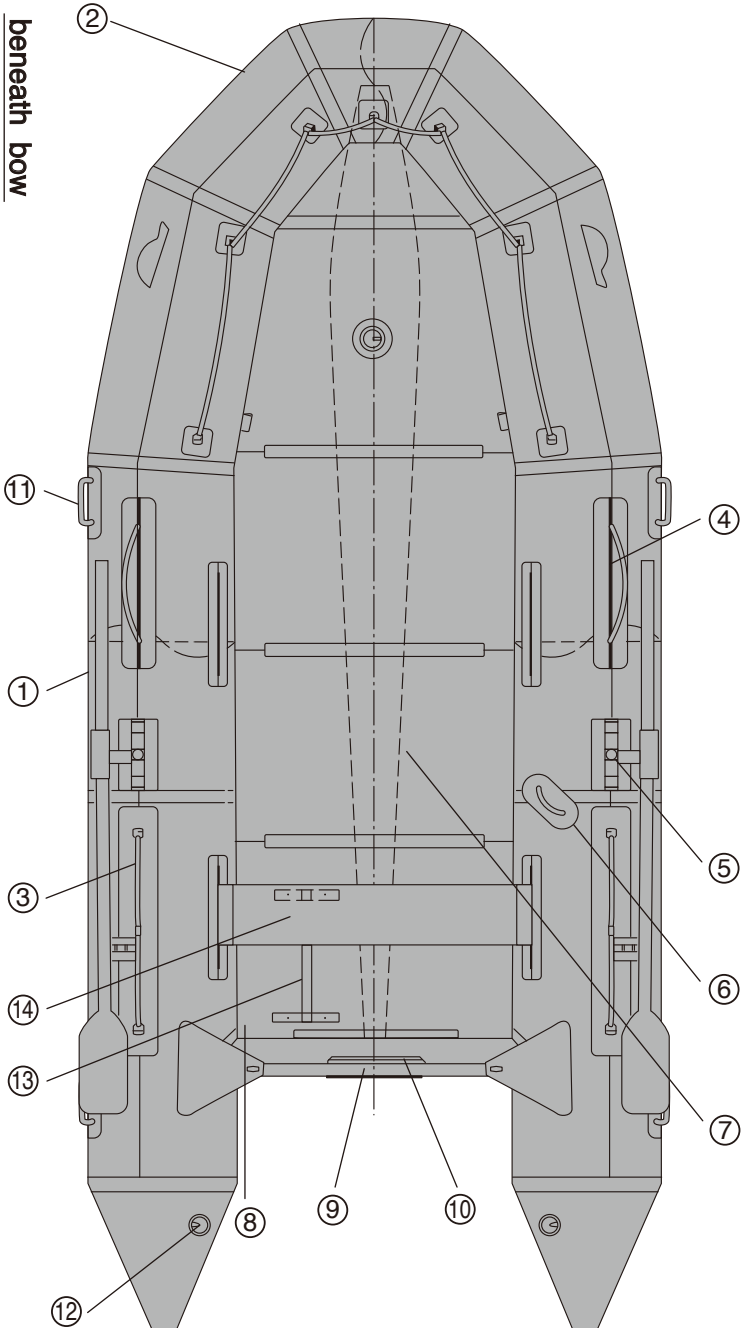

1. Reinforced rubbing strips of extra wide, heavy duty material for protection all around the boat.
2. Bow Ring/Carry Handle of metal, includes painter line on most models.
3. Life Lines-Easily reached from inside or outside the boat.
4. Spray Deflector Trim on some Sport Boat models can be utilized as an attaching cuff for accessories such as steering systems.
5. Lock-Type Oarlocks, Oars and Oar holders (Except Models 15'6" or longer)
6. A Helmsman's Grip for driving at high speeds on most models.
7. Heavy-Duty Marine Plywood Sectional Floorboards with High Gloss Finish, Aluminum Floorboards, or "AirFirm" Floor depending on models.
8. Self Bailer Drains with a rubber diaphragm one-way check valve.
9. Fiberglass or Wood Transom for strong support of high performance outboards.
10. An aluminum pad to protect the transom and prevent engine "Ride Up".
11. Lifting Handles for easy carrying on most models.
12. Extra Large one-way, air-tight check valves for quicker inflation and deflation.
13. A Fuel Tank Fastener to solidly secure fuel tanks and prevent movement on some models.
14. Removable seat on most models.

REMARKS: The features and equipment on this page are not standard on all models. Achilles reserves the right to change specifications and standard items without notification.

ACHILLES BOW HANDLE (SU/SG/SGX)

⚠ CAN NOT BE USED TO PULL BOAT ONTO TRAILER BY A WINCH.

CORRECT USE

When tying a rope to bow handle, Tie rope only to ring on handle.



DO NOT USE HANDLE TO WINCH AND SET ON TO TRAILER

INCORRECT USE

Never tie rope to this part of handle. This is designed only for lifting by hand.



Only the Towing Drings Should be used for towing the boat or pulling the boat on to a trailer by a winch.

Note: To determine which features are standard on a particular model, please refer to Achilles brochure or check with your Achilles Dealer.

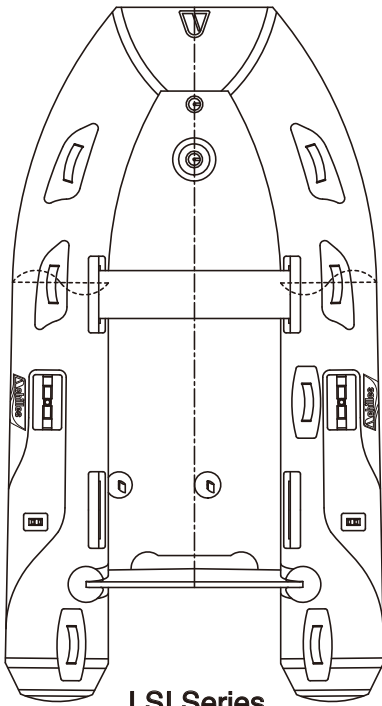

LSI Series

Air-Firm Floor(LSI)

Maintenance / Dismantle of Achilles Air-firm Floor (LSI)

Deflate the boat and floor. Remove and re-install as this way.

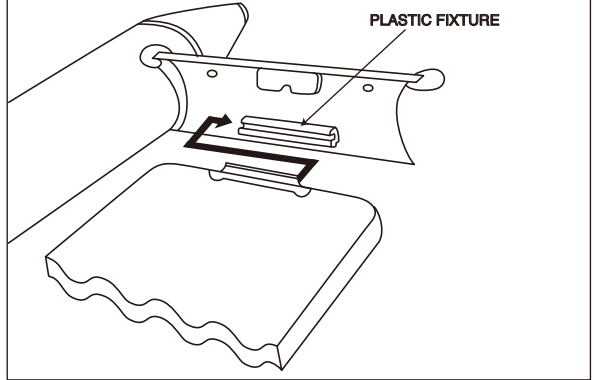

Aluminum Roll-up Floor(LSR)

Maintenance / Dismantle of Achilles Aluminum Roll-up Floor (LSR)

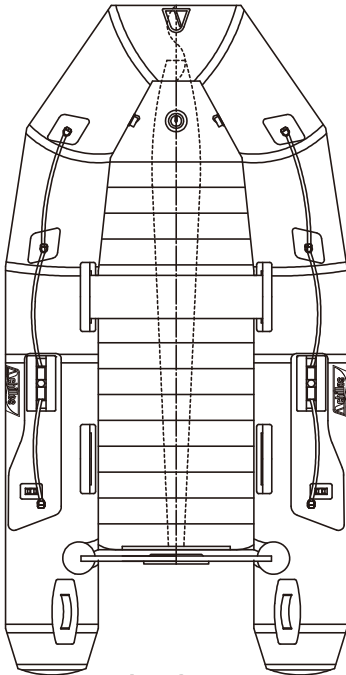
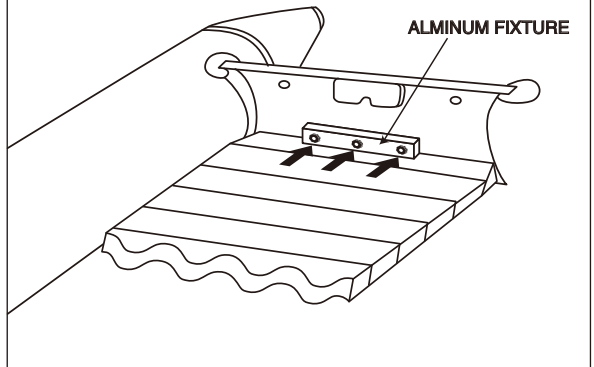

LSR Series

Roll-up Floor

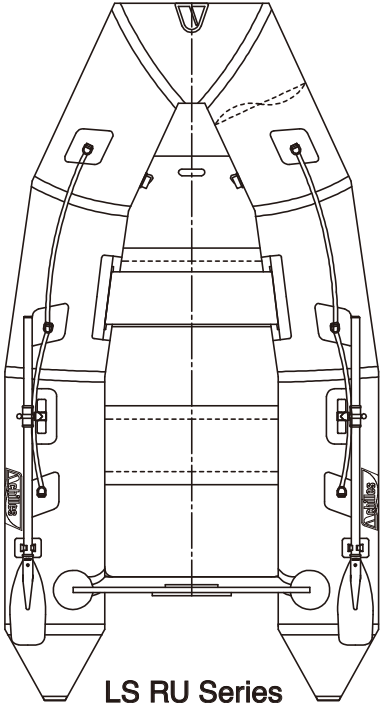

RIB

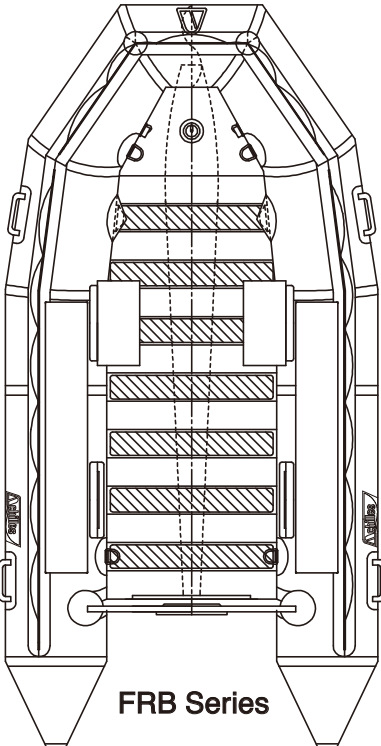
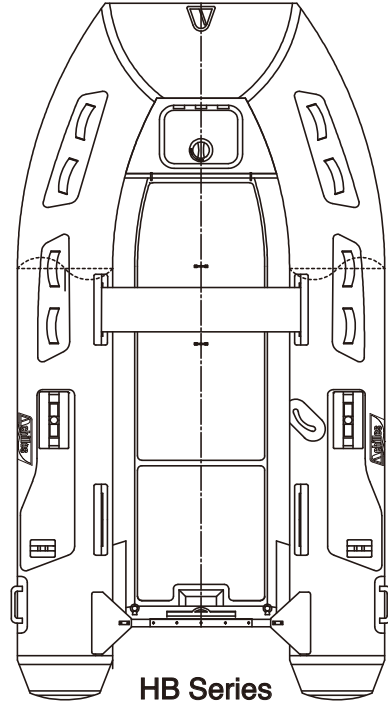

Aluminum Roll-up Floor (FRB)

Maintenance / Dismantle of Achilles Aluminum Roll-up Floor (FRB)

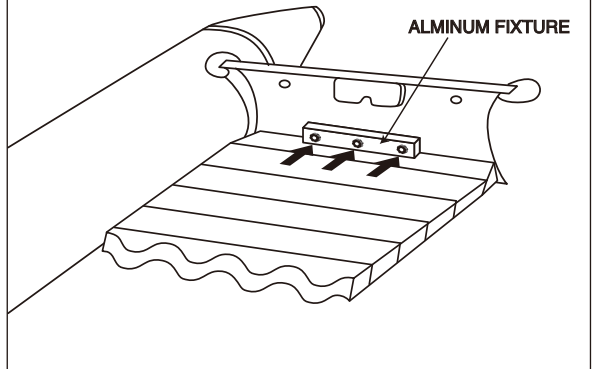

* MAXIMUM PRESSURE OF FRB MAIN TUBE : 0.22bar 3.25 PSI

ASSEMBLY

(FLOORBOARDS)

The floorboards must be put in BEFORE the boat is inflated. The first time you try to fit the floorboards inside the boat they may seem too large. This is normal and happens because the boat is still new and has not yet been broken in. After your boat has been assembled once or twice, the floorboards will fit in easily. When assembling for the first time, inflate the hull without the floorboards in place and let the boat sit from 12 to 24 hours (see inflation instructions). This will stretch the material just enough so that when the boat is deflated you can fit the floorboards in easily. Application of a soapy water solution on the inside of tubes where they meet the floor will help floorboards slide into position. To install the floorboards, follow the instructions.

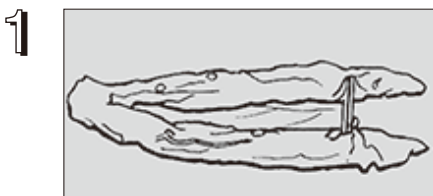
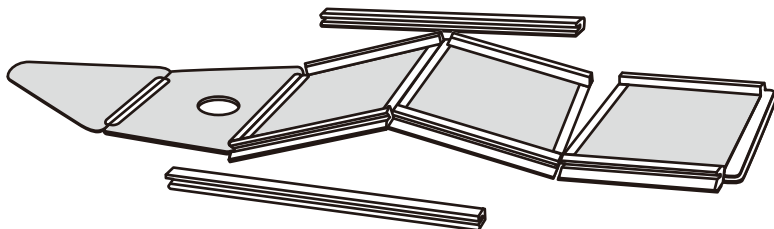

On a large, flat smooth surface fully spread your Achilles out. Make sure the entire surface is clear of all sharp rocks and other abrasive materials. Insert all valves. Partially inflate the boat (see inflation instructions)." In case of LSR series and LSI series, please inflate completely based on inflation procedure (Page 12 and 13)."

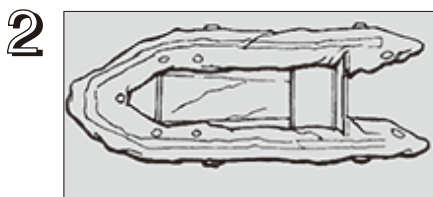

Insert the floorboards with the printed numbers facing up. Push the No. 1 floorboard firmly into the bow until it reaches the point. You will have to lift the bow tube to do this. The stern board (No.4) or (No.5) fits under the transom stopper. When these sections are in place, SLOWLY and FIRMLY push them into position with your feet.

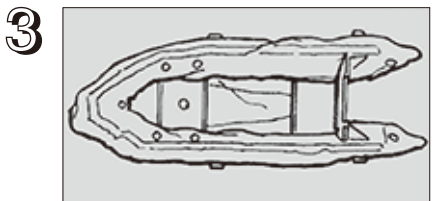

Next, place the No.2 floorboard, fitting the hole over the air keel valve. Insert the planed edge of the No.2 floorboard into the groove of floorboard No.1.

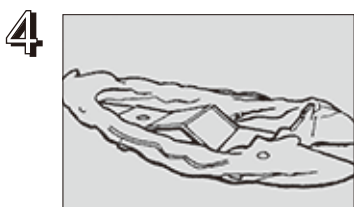

Finally, set in the No.3 and No.4 floorboards, forming a "V" shape. Make sure that all the floor sections line up at the edges.

NOTE: On models with only 4 floorboards, we use this step for No.2 and No.3 Boards.

5



With all floorboards in position, step firmly and slowly on the joint until the boards are securely in place. If necessary, push back on the transom. If the floorboards still do not fit, remove them and inflate the boat. Let it sit for about 10 minutes, then deflate and try again.

6

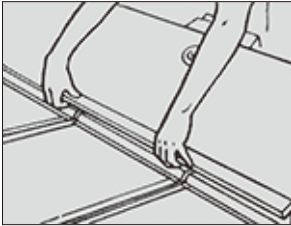

Attach the battens to the side of the floorboards. Fit the groove of the batten over the edge of the floorboard sections, positioning the batten between the two black rubber stoppers, or in between each side of the recessed portion of floorboards.

(INFLATION)

Achilles boats inflate easily in just minutes when you follow the proper instructions. The two major components of the inflation process are the foot pump and the valve system.

BELLOWS TYPE FOOT PUMP AND HAND PUMP

Use only the pump that is included with your Achilles. Never use a gas station air hose or other high compression pumps as they could cause structural damage to your Achilles. The pump should be placed flat on the ground. Use gentle, unhurried strokes making sure that the top of the bellows rises completely each time.



ACHILLES DOUBLE SAFETY VALVE SYSTEM

In order to make inflation quick and efficient, the Achilles valve has a wider diameter. Achilles uses special one-way valves so when the hose is pulled from the valve during inflation, no air will escape. When deflating the boat, simply unscrew and remove the entire valve assembly. (SU models have a heavy duty valve. This is not a one-way valve.)

Bilge Drain with Check Valves: Put the drain plug in on the bilge drain whenever the boat is afloat.

OPTIONAL PRESSURE GAUGE

Both over-inflation and under-inflation will cause premature wear and tear to your inflatable boat.

Achilles recommends the use of the optional pressure gauge prior to and during use of your inflatable boat.

INFLATING YOUR ACHILLES

- 1 Remove the top cap on the valve, making sure the bottom remains tight. Insert the air hose into the valve. Use **ONLY** the pump provided with your boat.



- 2 Starting at one valve, inflate each chamber in turn only a quarter of the way full. Repeat the cycle until each chamber is completely filled. By maintaining an even pressure on all air chambers you eliminate stress, and potential damage, on the inside diaphragms. When inflating the air keel, make sure you are not standing in the boat.

- 3 Recommended maximum air pressure is as follows. You can accurately measure the pressure with optional gauge.

MAX OPERATING PRESSURE

1. MAIN TUBE & INFLATABLE KEEL :	0.19 bar	2.8 PSI
2. INFLATABLE "AIRFIRM" FLOOR :	0.6 bar	8.7 PSI

Note: exact calculation will show slightly different figures, but for inflation purposes this small difference may be disregarded.

We strongly recommend the use of a pressure gauge if one is not included with your boat. Ambient temperature of air and water has a direct impact on the boats internal pressure. It is important to realize that because of temperature variations during the day (especially in hot climates) it is important to check the internal pressure and inflate or deflate the tubes to keep them at the recommended pressure (2.8 PSI for the main air chambers and 8.7 PSI for the high pressure air floor).

There is a risk of under pressure when you inflate your boat in direct sunlight on a hot day and then put the boat into (cold) water. You may have to re-inflate the boat after it is placed in the water. Also a slight loss of pressure at the end of the day when the temperature drops is normal.

There is a risk of over pressure when you inflate you boat in the morning when it is cool and then it is exposed to direct sunlight on a beach or on your deck. It is important in this scenario to regulate the internal pressure as it can double in some circumstances and possibly damage the internal baffles, the seams, or the fabric.

- 4 When deflating your ACHILLES, start with the air keel and turn the entire valve just enough to let the air escape slowly. Do this to all the remaining valves at the same time so that an even pressure is maintained as your ACHILLES deflates. Force any remaining air out of your ACHILLES by completely unscrewing the valves and folding your ACHILLES slowly in one direction.

LSI Inflation Procedure



Fig. 1 Low Pressure Hose Position Fig. 2 High Pressure Hose Position

When inflating the LSI Series boats with the Bravo-9 foot pump, the following procedure should be followed to insure proper inflation obtained.

1) Main Tubes

Insert the small black cap into the center hole and use the pump with the hose in OUT marked position. Pump the tubes up to 2.8 lbs pressure. Pressure can be determined by gauge on pump hose. (See fig.1 for detail.) In this case, the small black cap should be inserted into the center hole.

2) "AirFirm" floor

Using the same pump position as used step one, pump up "AirFirm" floor to 2.8 lbs pressure with the black cap inserted, then remove the small black cap and pump floor up to 8.7 lbs pressure. Use pressure gauge to determine correct pressure. (See fig.2)

3) Inflatable Keel

Insert the black small cap into the center hole, and inflate keel to 2.8 lbs pressure (See fig.1)

HOW TO ATTACHED WOODEN OR ALUMINUM SEAT

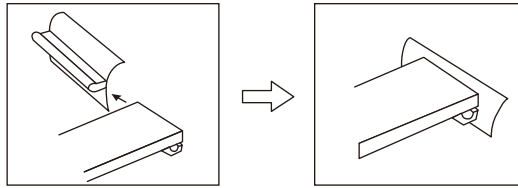

Please fix to move through the loop of molded rubber before the boat in fully inflated.

(MOTOR MOUNT BRACKET B-TYPE (LT-2))

The motor mount bracket shall be fixed after the boat is inflated.

(1) The bracket is made of two pieces. of marine plywood-one. (A) has a cutout hollow at one end and (B) has a thicker end on which the motor can be mounted. They are joined together by a metal hinge which forms a "T" Shape.

(2) Hold an end of (A) board in horizontal position and (B) board in upright position with the thicker end up. Push (B) board down through the rubber becket attached to the outside of the boat stern until you see the very end stopper rail pushed out of the becket.

(3) And then, adjust (A) board location on the stern tube so that the eyelets of the outside hem on the stern tube can stick out completely through the hollow cutout and can be fastened with another side hem with the lace provided in the package.

(4) Fasten together securely with lace through each eyelet. If mount is not laced up tightly, the bracket may cause damage to the hull or the motor may fall off.

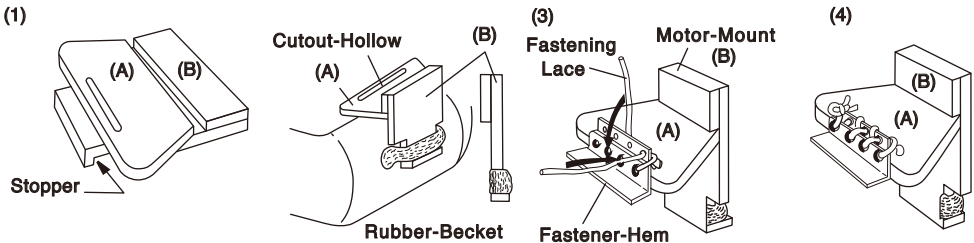

MAKE SURE THE LACE IS TIGHTENED COMPLETELY

You may deflate and store the boat temporarily with motor bracket laced on, but be sure to get the bottom end of (B) board off the rubber becket. If you plan on storing inflatable for a long time ,we recommend removing the motor mount bracket.

(MOTOR MOUNT E-TYPE)

The motor mount must be placed into position BEFORE the dinghy is inflated. The motor mount bar fits underneath the rubber stopper attached to the stern of the boat.

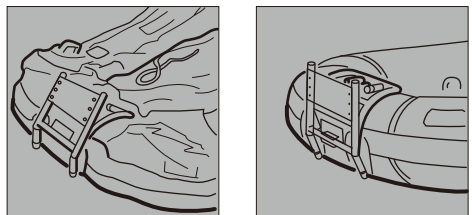

INFORMATION FOR OUTBOARD MOTOR

When choosing the size of outboard motor for your Achilles, you must of course consider the use you'll put it to. It is, however, dangerous and unlawful to use a motor that exceeds the maximum horsepower limits for your boat. The extra weight as well as the resulting vibration of a larger motor will prevent any improved performance.

MOUNTING THE MOTOR

Unlock motor and mount as indicated in the diagram.

The motor should be centered in the middle of the transom.

Tighten the clamps thoroughly. Periodically check the clamps for tightness once you are underway. Engine vibration can cause the clamps to loosen.

Before tilting your motor, disconnect the fuel line and allow the motor to run until the carburetor is dry. This will ensure that no fuel will spill onto your Achilles when the motor is tilted or taken off its mount.

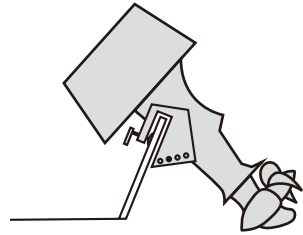

ADJUSTMENT OF OUTBOARD MOTOR

It is very important that the angle adjustment of your motor in relation to the transom is correct in order to ensure maximum performance of your Achilles.

Generally, the center of your propeller should be parallel to the surface of the water when the boat is planing.

If the outboard motor is too far away from the transom the boat will tend to bow up when you start off. If it is too close to the transom, the boat will tend to ride nose down. Adjustments may vary for the same outboard motor depending on the weight and position of the load and the conditions of the sea. Under normal conditions, place the regulation index of the motor on the 2nd hole from the transom.

The height of the outboard motor also affects the performance of the boat. When used for certain purposes (speed, carrying heavy loads, etc.), a wooden batten may be placed on top of the transom in order to raise the engine. An outboard motor positioned too high will tend to slip on sharp turns. Installed too low, it may cause water to splash into the boat over the transom.

You may have to make several adjustments before you find the best position for your motor. It is a matter of trial and error, but if you have any specific questions, contact the dealer where you purchased your motor.

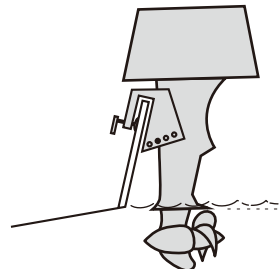
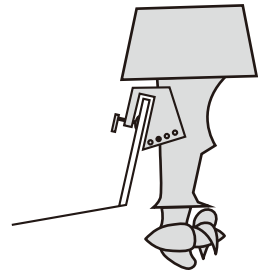

OPTIONAL EQUIPMENT

- Pressure Gauge
- Fiberglass Console and Seat
- Wood or Aluminum Seat
- Aluminum and Plastic Oars
- Stainless Steel folding seat/console

MAINTENANCE

Before storing your Achilles away for long periods of time, you should thoroughly clean it to remove salt water residue, dirt, and abrasive sand particles. While the top-quality materials that are used in the construction of your Achilles Inflatable will stand up to most rough treatment, it is best to follow a routine maintenance program. Proper care and maintenance are also necessary to keep your warranty intact.

- 1** Deflate your Achilles and remove the floorboards or air firm floor. Reinflate.
- 2** Vacuum hose or brush off any sand or other debris from the boat's interior, especially where the tubes meet the floor.
- 3** Wash both the interior and exterior with a mild soap and FRESH water. Rinse thoroughly with fresh water. This procedure is usually sufficient to remove most dirt; however, with more stubborn stains a scouring or soap pad may be used with care. A protective chemical treatment, may also be applied as a precautionary measure against such stains, however, be sure to avoid using any silicone based products as it may impair ability to repair boat or adhere any attachments in future.
- 4** Allow your boat to dry thoroughly in the shade, not in the direct sunlight. Lean the boat against a support with the floor bottom facing outward.
- 5** When your Achilles is completely dry, roll it up loosely and store in a cool, dry place away from sunlight. To fold up your Achilles for storage unscrew all the valves entirely from the boat and leave out. Turn both side tubes inward to the center of the boat. Fold the stern toward the bow one third the length of the boat. Fold the bow over the stern and place in the carrying bag.
- 6** If you are storing your Achilles on the deck of your boat for even the shortest time during the day, release some of the air from each of the chambers. This prevents damage from over-inflation which can occur when the heat from the sun causes the air inside the chambers to expand.

REPAIRS

A repair kit is included with your Achilles boat for patching minor punctures.

- 1** Locate the entire puncture by inflating boat to normal operating pressure apply a soapy water solution to the entire boat while looking for escaping air bubbles.
- 2** Mark the spot and deflate the air chamber.
- 3** Cut out a round edged patch that will overlap the puncture by one inch on all sides.
- 4** Clean the fabric around the puncture with Acetone. CAREFULLY sand both the damaged area and the patch with a mild sandpaper. When sanding, you want to rub off the layer of C.S.M. until a dull finish appears so that the adhesive will stick to the nylon or the tube properly. The patch is made of the same C.S.M. material so your boat will be protected when the repair is completed.
- 5** After sanding, reclean the area with Acetone and allow to completely dry.
- 6** Apply two coats of adhesive to the patch and the damaged surface, allowing the first coat to dry completely before applying the second coat which should dry until tacky.
- 7** When the final coat feels tacky, place the patch firmly over the puncture, making sure that it is entirely covered by the patch.
- 8** Smooth out the patch with a rounded object (a spoon works well) to remove any trapped air bubbles.
- 9** Allow the repair to set for 24 hours before inflating and testing it.

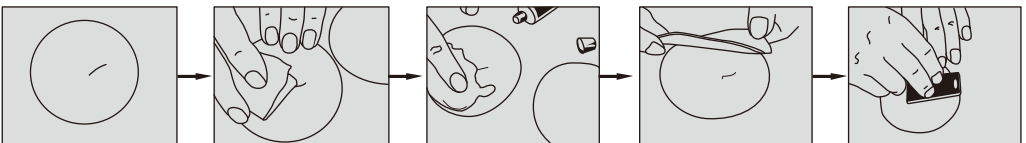

THINGS TO REMEMBER

Towing Recommendations:

Do not tow with outboard engine attached. Tow only with soft rope.

If your boat is to be towed frequently, it is best to use the towing "D" rings (if installed) (one on each side of boat) so that along with the bow towing ring, all three share the stress. If you do not add tow rings, it is best to loop tow line around wooden transom (inside the pontoons) and then under bow through front "D" ring. This will make the boat tow easier without plowing.

To inflate, use only the foot pump or hand pump provided with your boat.

Do not overinflate. Doing so can cause interior structural damage to the air chambers. Recommended maximum air pressure is 2.8 lb/in² (0.2 kg/cm²).

To deflate, unscrew both valve caps together in each chamber. Fold the boat slowly from both ends until all the air is expelled.

After inflation, routinely inspect your boat before putting it in the water. Check for airleakage. Any punctures should be repaired immediately. Also see that the wooden floors and motor mount have been properly installed.

Inform yourself of local rules and regulations concerning the use of your boat prior to casting off.

It is advisable to carry a fire extinguisher on board suitable for extinguishing petrol fires.

When choosing an outboard motor for your boat, it is advisable to check that it has a start-in-gear protection as well as an emergency shut-off that can be tied to the wrist when operating the outboard.

CAUTION-Because the air volume inside the tubes expands as the temperature rises, the air pressure may fluctuate depending on the weather conditions. For example, a boat that is properly inflated in the morning may become overinflated at midday when the sun is hotter. Or a boat, properly inflated during the afternoon, may need more air later in the evening when the temperature is cooler. Always be aware of the pressure of your boat. You can get an accurate reading with the optional gauge.

Reduce speed in congested waterways and in weather and sea conditions exceeding the full throttle capacity of the craft.

Exhaust Emissions

You can be overcome by fumes from your own engine in a confined space or from neighbouring boats in a close mooring situation. Ensure continuous movement of fresh air.

DANGER EXTREME HAZARD-

Ensure adequate ventilation. Gasoline powered engines produce odorless and colorless carbon monoxide gas (CO²).

Prolonged exposure can cause serious injury or death. Symptoms include dizziness, nausea, drowsiness. The following conditions require special attention:

- Operating at slow speed in calm air and sea conditions.
- Operating with the bow high.
- Operating engine and/or generator in confined spaces. Be aware of possible CO² from nearby boats in a confined docking area.
- Winds blowing exhaust toward boat occupants.

SAFETY GUIDELINES

Life jackets should be worn at all times while boating and a lifeline kept secured to the boat.

Keep a well-maintained engine. Make sure the mount is fastened securely and as an extra precaution, tie the engine to the boat with some rope. Before leaving the dock, check your fuel level.

Always carry oars on your boat in case of engine trouble and a foot pump to maintain proper air pressure.

Carry engine tools, ropes, anchor, bailer, and extra fuel when on extended trips.

Immediately wipe off any engine oil that drips on your boat.

After leaving the dock, secure the mooring line to the inside of the boat. It is dangerous to allow a mooring line to trail in the water as it could become entangled in the propeller.

Avoid rough contact with piers or other abrasive wall surfaces. When approaching a dock, cut the engine and fend off the boat.

Accelerate slowly when starting out. When two or more people are in the boat or when carrying heavy cargo, be careful of the load distribution.

When the boat is nose-up before planing, keep the weight toward the bow of the boat. Too much weight in the stern when accelerating could cause the boat to over-turn when the wind is blowing toward you. Reduce speed when turning. The boat will naturally tilt toward the inside of a turn, so adjust your weight accordingly.

Emergency Reboarding Procedure

Make sure motor is off. DO NOT approach boat or transom if motor is running. Use any available handles to assist you in reboarding. If someone is still on the boat, they should assist you while maintaining proper weight distribution to avoid capsizing or swamping. Re board at or near the stern if possible, which is the lowest part of the boat. It is advisable to always carry an emergency boarding ladder or similar device in your dinghy.

Warning labels (for USA customers only)

For aid in replacement of lost or ineligible warning labels.

CO Transom Label (NW 206) One should be on the inside and outside of the transom in a position so that the mounting of an outboard engine will not interfere with the ability to view the label.

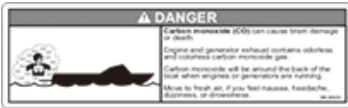

This label is required on all boats sold in the state of California in accordance with AB2222. It reads “Carbon monoxide (CO) can cause brain damage or death. Engine and generator exhaust contains odorless and colorless carbon monoxide gas. Carbon monoxide will be around the back of the boat when engines or generators are running. Move to fresh air if you feel nausea, headache, dizziness or drowsiness.”

Prop Transom Label (NW 208) One should be placed on the inside and outside of the transom in a position so that the mounting of an outboard engine will not interfere with the ability to view the label.

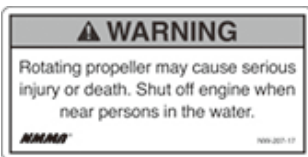

This label is required in ABYC H-41. It reads “Rotating propeller may cause serious injury or death. Do not approach or use ladder when engine is running.”

These labels (if missing) can be purchased from the NMMA on their online store.

These labels are specific for lettering and colors. The color has to be:

DANGER – black or white letters on a yellow background

NOTE: Black letters on a red background for exterior applications, where the label is exposed to sunlight or red (night) light.

WARNING – black or white letters on an orange background

NOTE: Black letters on an orange background for exterior applications, where the label is exposed to sunlight or red (night) light.

The minimum height of letters in the message panel has to be of 1/8” or 3.22 mm to have a visibility of the text from 5 feet, or 1.5 meters or less. The signal letters should also be at least 1.5 times as high as the upper-case letters in the message panel.

SEATING GUIDE LINES

Be sure to ALWAYS observe manufacturer's recommendations for maximum capacities for persons, motor HP rating and gear. Always wear a lifejacket. For safe operation it is recommended to have people sit in the middle of the boat or on any installed seats as much as possible. Small children should always be sitting IN the boat. The front bow area (tube) or transom should never be used for seating. Unexpected acceleration or deceleration or any abrupt movement could cause occupants not properly seated to be thrown overboard from the boat or into the boat resulting in a dangerous situation. If someone is sitting on the sides of the boat, it is important that they use lifelines and handles for safety and also that you try to offset their weight with someone on the opposite side of the boat for stability. Because inflatable boats are so light, proper seating and weight distribution is critical for performance and safety.

Achilles inflatables weigh relatively little so it is not necessary to have a large engine to power your boat. An oversized engine often does more harm than good. Please refer to the recommended and maximum HP chart.

Since your boat is lightweight, it will be affected by wind, tide current, and the rolling and pitching of waves. Factors such as weight distribution will also affect the boat's performance. Keep in mind the boating conditions you will encounter when you load your boat.

Water may get inside your boat when riding at high speeds or in rough seas, but there is no danger of sinking. Always carry a bailer or small bucket in your boat. Some sportboat and sport dinghy models are equipped with a self-bailer with a check valve so that water removal is automatic when planing. Extra clothing and other personal articles should be protected in waterproof bags.

Be cautious when boating in shallow water or around hidden reefs. Sharp objects such as shells, glass or rocks can cause punctures. Because Achilles boats have two or more air chambers, sinking is not a risk. If one tube does accidentally deflate, move to the side of the boat that is still inflated and slowly head for shore.

Avoid dragging your boat over rocks or abrasive ground.

Do not leave your boat exposed to sunlight for extended periods of time. High temperatures could increase the air pressure inside the hull chambers causing the tubes to expand, seriously damaging the seams.

NOTICE

It is illegal for any vessel to dump plastic trash anywhere in the ocean or navigable waters.

Excessive noise

Some areas have regulations establishing noise limits, which can be applied to boats. Even if there are no such laws in your area, courtesy to others demands that boats be operated quietly.

Wake/wash

Powerboat wakes can endanger other craft, particularly sailboats. Be especially careful of other boats in confined areas such as channels or marinas. Observe 'no wake' warnings.

Fuel and oil spillage

Regulations prohibit the discharge of fuel or oily waste in navigable waters. Discharge is defined as any action which causes a film or sheen or discoloration on the surface of the water, or causes a sludge or emulsion beneath the surface of the water. One of the most common violations occurs when bilge water is discharged. Use rags or sponges to soak up fuel or oily waste, then dispose of it properly ashore. Do not pump oily bilge water overboard.

Waste disposal

Place all refuse in bags or containers and store on board until they can be disposed onshore. Regulations prohibit disposal of plastic garbage anywhere in the marine environment. Regulations also restrict disposal of other types of garbage within specified distances from shore.



ACHILLES INFLATABLE BOATS

LIMITED WARRANTY

Warranty Coverage

Achilles Corporation C/O Achilles Inflatable Boats (A Division of Achilles USA, Inc.) hereafter called "Achilles" makes the following warranties to the **original purchaser**, hereafter called "YOU", of an Inflatable Craft manufactured by it:

1. Warrants the seams of the ACHILLES hull for a period of five (5) years from the date of original purchase against separation and subsequent loss of air.
2. Warrants the fabric used in the construction of the hull, keel (where installed), and bottom of the inflatable boat against defects in workmanship and materials for a period of five (5) years from the date of original purchase. Fabric discoloration due to any cause is not a warranty consideration.
3. The transoms and motor mounts on all Achilles boats are warranted for one year. In addition, the transom on all Achilles Inflatable Boats (where permanently installed), is warranted against separation from the hull for a period of one (1) year from the date of original purchase. However, this warranty is voided if an outboard motor in excess of the maximum horsepower listed on the data plate fastened to the transom is used to power or propel the boat
4. Fiberglass Hull, "Air Firm" floor, floorboards, oars, handles, towing rings, rubstrake, and all other ACHILLES attachments or ACHILLES accessories attached to or purchased for attachment to or for use on Achilles Inflatable Boats are warranted for a period of one (1) year from the date of the original purchase against defects in workmanship and material. This includes the mechanical attachment of all such attachments and/or accessories. If, within the warranty periods set forth above, your new Inflatable Boat is proved to ACHILLES' satisfaction to be defective, non-conforming parts will be repaired without charges for parts or labor, or replaced, at ACHILLES' option.
5. The structure of the Aluminum hull on Achilles Inflatable Craft is warranted to be free from manufacturing defects for a period of 2 years. This warranty excludes consequential damage to the hull from negligence, lack of proper maintenance, or misuse. This exclusion includes any modification the hull and/or transom and the use of an outboard motor in excess of the rating on the specification plate on the transom. Environmental damages due to electrolysis (or any corrosive water environment), exposure due to pollution, hail, acid rain, industrial pollution, tree sap, lightning, etc. additionally are excluded from this warranty.

Other Limitations or Exclusions

1. This warranty is extended only to you, the original purchaser, and this warranty may not be transferred or assigned. If the Achilles Inflatable Craft is used in/for a commercial application, the entire boat (all applicable warranties) will only be honored for a period of 1 year from original date of purchase.
2. This warranty shall not apply to Inflatable Boats subjected to negligence, accident, improper operation or trailering, improper maintenance or storage, or other than normal use or application as described in the Achilles Inflatable Instruction Manual, or to damage by circumstances beyond ACHILLES control.
3. This warranty does not cover damage to the Inflatable Boat because of puncture, tearing, ripping, abrasion, ordinary wear and tear, abuse, negligence, or modification to the hull and/or transom. Additionally, moisture damage to wooden parts (transoms/seats/floorboards) or composite assemblies (floorboards/transoms) due to failure to maintain protective coating (paint, varnish, fiberglass) is also excluded from warranty coverage. These wooden/composite parts must also be kept in a way that prevents them from being continually submerged.

4. Consequential damages resulting from warranty considerations are excluded. These include but are not limited to loss of use, haul out and re-launch, rigging/de-rigging (if applicable), transportation to/from an authorized warranty repair center, loss of income (commercial application), and any rental fees that might be incurred.
5. ACHILLES LIMITS ALL IMPLIED WARRANTIES TO ONE (1) YEAR FROM THE DATE OUR BOAT WAS ORIGINALLY PURCHASED AT RETAIL. (Some states do not allow limitations on how long an implied warranty lasts, so the above limitation may not apply to you).

Warranty Claim Procedure:

All warranty claims must be made through an Achilles dealer within thirty (30) days after discovery of a defect and submitted on the ACHILLES warranty claim form by the dealer together with proof of purchase. Photographs illustrating damage, if any, must accompany the claim. An inspection may be made, within a reasonable time, by an authorized representative, after receipt of the claim. When a warranty claim is valid, ACHILLES will repair, have repaired, or at its option, replace the Inflatable Boat or defective part free of charge. Freight and transportation charges, where applicable, incurred in shipping a boat to be repaired or replaced are to be paid by consumer purchaser.

OTHER IMPORTANT INFORMATION:

1. The Federal Boat Safety Act of 1971 provides for defect notification to the first purchasers. Failure to register your purchase with the manufacturer constitutes waiver of the right to defect notification. ACHILLES can not fulfill its obligation under this important ACT without your cooperation. Please complete and mail the self-addressed Owners Registration Card accompanying your boat.
2. ACHILLES reserves the right to make changes in the design and material of its Inflatable Boat without incurring any obligations to incorporate such changes in units already completed or in the hands of dealers or consumers.
3. The entire obligation of ACHILLES regarding the sale of its Inflatable boats is stated within this written warranty. ACHILLES does not authorize its dealers or any other person to assume for it any other liability in connection with the sale of its Inflatable Boats.
4. The warranties hereinbefore set forth are made to you by the manufacturer, ACHILLES CORPORATION, C/O ACHILLES INFLATABLE BOATS (A Division of Achilles USA, Inc.). If for any reason you are unable to locate an Achilles dealer or if the dealer does not provide satisfactory warranty service, contact ACHILLES INFLATABLE BOATS, A Division of Achilles USA, Inc., PO Box 2287, Everett, WA 98203, USA.

This warranty is not transferable and not valid not registered.
Please return this registration card within 15days after purchase.

MODEL NUMBER : _____

HULL IDENTIFICATION NUMBER : _____

***Receipt of documents**

The first owner of the boat has signed this receipt or documents, thereby stating that all papers and the boat with all parts are supplied in good order.

DATE : _____

NAME : _____

SIGNATURE : _____

ADDRESS : _____

TELEPHONE : _____

PLACE OF PURCHASE : _____

The total number of pages in the manual is 24 including the back page.

MANUFACTURED BY:
Achilles Corporation
22F, No. 2-21-1, Kitashinjuku,
Shinjuku-ku,
Tokyo, Japan 169-8885
Phone : (03) 5338-9363
FAX : (03) 5338-9369

Printed in Japan